

## WFDT/WFDTH Vane-type Waterflow Detectors

### Specifications

Contact Ratings:		Two sets of SPDT (Form C) 10 A @ 125/250 VAC; 2.5 A @ 24 VDC
Triggering Threshold Bandwidth (Flow Rate):		4 - 10 GPM
Static Pressure Rating:		250 PSI (Max.)
Dimensions, Installed:	WFDT -	4 <sup>5</sup> / <sub>16</sub> "H × 3 <sup>3</sup> / <sub>4</sub> "W × 6 <sup>3</sup> / <sub>4</sub> "D
	WFDTH -	4 <sup>5</sup> / <sub>16</sub> "H × 3 <sup>9</sup> / <sub>16</sub> "W × 6 <sup>3</sup> / <sub>4</sub> "D
Operating Temperature Range:		32°F - 120°F (0°C - 49°C)
Shipping Weight:		2.6 lbs.
Enclosure Rating:	WFDT -	NEMA Type 4, as tested by Underwriters Laboratories, Inc. (U.L.)
	WFDTH -	Indoor use only, as tested by U.L.

The WFDTH can be installed between 2X4 stud wall construction.

U.S. Patent Number: 5,213,205; 4,782,333; 3,845,259

### Important

#### Please Read Carefully And Save

This instruction manual contains important information about the installation and operation of waterflow detectors. Purchasers who install waterflow detectors for use by others must leave this manual or a copy of it with the user. Read all instructions carefully before beginning.



Use vane-type waterflow detectors in wet-pipe systems only. DO NOT USE IN DRY-PIPE, DELUGE, OR PRE-ACTION SYSTEMS. The sudden inrush of water in such systems may break the vane off or damage the mechanism. Do not use in potentially explosive atmospheres. Do not leave unused wires exposed.

### Principles Of Operation

Vane-type waterflow detectors mount to water filled pipes in sprinkler systems. Water flow in the pipe deflects a vane. Deflection of the vane produces a switched output, usually after a specified delay.

All WFDTs have a pneumatically controlled mechanical delay mechanism. Delays are noncumulative; they reset if the flow of water stops before the entire delay has elapsed. All detectors will activate on a sustained flow of water greater than 10 gallons per minute (gpm) but will not activate if the flow rate is less than 4 gpm.

### Compatible Pipe Tees/Risers

The WFDT and WFDTH fit 1" to 1<sup>1</sup>/<sub>2</sub>" NPT threaded ferrous and brass, 1" to 2" sweat brass, 1<sup>1</sup>/<sub>2</sub>" polybutylene plastic and 1" pvc plastic tees having a 1" threaded NPT branch (see Figure 1 and chart for recommended tee depths). For 2" cast and malleable threaded tees use 2" paddle (p02-0023-000) provided.

Approximate Tee Depth Requirements (See Figure 1)						
Tee Depth	Threaded	Sweat	Poly B	CPVC	CPVC/Spears	CPVC/Central
1 × 1 × 1"	2 <sup>1</sup> / <sub>8</sub> "	1 <sup>3</sup> / <sub>4</sub> "	N/A	2 <sup>1</sup> / <sub>4</sub> "	2 <sup>15</sup> / <sub>32</sub> "	2 <sup>13</sup> / <sub>16</sub> "
1 <sup>1</sup> / <sub>4</sub> × 1 <sup>1</sup> / <sub>4</sub> × 1"	2 <sup>1</sup> / <sub>2</sub> "	2 <sup>1</sup> / <sub>6</sub> "	N/A	N/A	N/A	N/A
1 <sup>1</sup> / <sub>2</sub> × 1 <sup>1</sup> / <sub>2</sub> × 1"	2 <sup>3</sup> / <sub>4</sub> "	2 <sup>1</sup> / <sub>4</sub> "	2 <sup>1</sup> / <sub>2</sub> "	N/A	N/A	N/A
2 × 2 × 1"	3 <sup>1</sup> / <sub>4</sub> "	2 <sup>3</sup> / <sub>4</sub> "	N/A	N/A	N/A	N/A

**Figure 1. Mounting dimensions:**

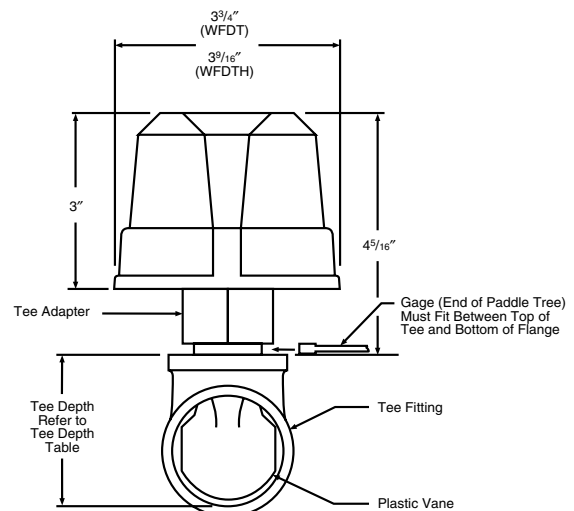

W0126-00

### Installation Guidelines

Before installing any waterflow alarm device, be thoroughly familiar with:

- NFPA 72: *National Fire Alarm Code*
- NFPA 13: *Installation of Sprinkler Systems*
- NFPA 25: *Inspection, Testing, and Maintenance of Water-based Fire Protection Systems*
- NFPA 13D: *Standard for 1 and 2 Family Dwellings and Manufactured Homes*
- NFPA 13R: *Standard for Multi-family Dwellings*

**Figure 2. Assembly diagram:**

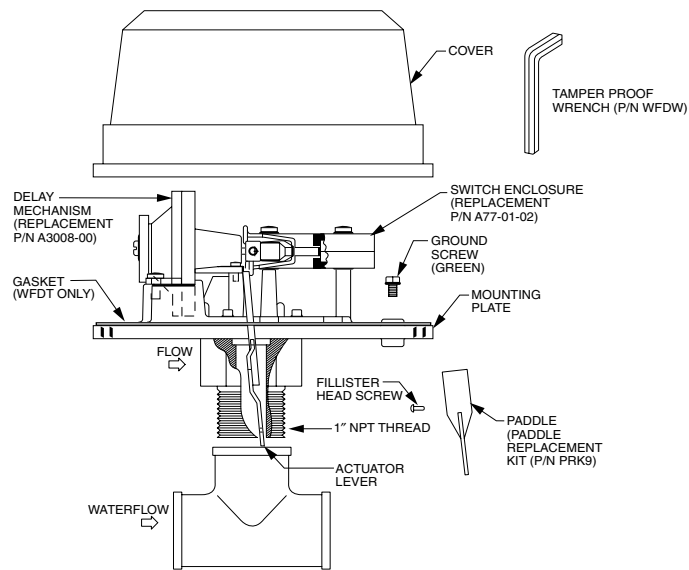

W0127-00

(Cover tamper option is available.)

Also, follow other applicable NFPA standards, local codes and the requirements of the authority having jurisdiction.

Failure to follow these directions may result in failure of the device to report a waterflow condition. System Sensor is not responsible for devices that have been improperly installed, tested or maintained.

1. Mount the detector where there is adequate clearance for installation and removal and a clear view of it for inspection. See Figure 1 for mounting dimensions.
2. Locate to protect from damage, 6-7 feet above the floor.
3. On horizontal runs, position the detector on top of the pipe or on the side of it. Do not mount it upside down because condensation may collect in the housing and impair the operation of the detector. For vertical flow applications, mount detector on pipe where upflow conditions exist. Failure to do so may prevent unit from operating properly.
4. Mount detector at least 6 inches from a fitting which changes the direction of the water flow, or no closer than 24 inches from a valve or drain.
5. BE SURE DIRECTION-OF-FLOW ARROW MATCHES ACTUAL DIRECTION OF FLOW IN THE PIPE.

### Mounting Instructions

1. The WFDT and WFDTH waterflow detectors are designed to fit only the appropriate tee fitting.

**NOTE:** Leg of tee perpendicular to flow of water must have a 1" NPT thread. Do not use a reducer to achieve the correct thread size. Failure to follow this instruction will result in failure of the detector to report a waterflow condition.

2. WFDT and WFDTH units are shipped without paddles mounted to the actuator. Select the correct size paddle for the type of tee being used. Align hole on stem of paddle with hole on actuator lever. Fasten together using a #4-40 x 1/4" fillister head screw supplied in bag assembly. See Figure 2. Use only the screw provided with the unit. Drive screw head through hole in paddle until it seats to actuator lever surface. No washer is required. For paddle replacement refer to Maintenance section.
3. Carefully roll the vane opposite the direction of flow and insert through tee. Thread detector onto tee fitting and tighten with wrench. Use of thread sealant or tape is recommended. Use height gage (located at end of paddle tree) to ensure proper depth of detector on tee fitting. See Figure 1. Height gage must fit between top of tee fitting and under side of hex tee adapter. A gap between gage and tee adapter is acceptable. When correctly installed, the detector must face in the proper direction of waterflow and be aligned with the pipe.
4. Remove the metal cover. Move the actuator lever back and forth to check for binding. If the vane binds, remove the detector and correct the problem before proceeding.

### CAUTION

Be sure the direction-of-flow arrow points in the right direction, otherwise a waterflow condition will go unreported. See Figure 2.

### Preoperation Testing

1. Fill the sprinkler system with water and check for leaks around the WFDT or WFDTH. If there is a leak, check to see that the fittings are tight. If leak persists, drain the system and remove the detector (see removal instructions under Maintenance). Check for damaged threads or cracked fitting. Reinstall the detector and check again for leaks. Do not proceed until all leaks have been stopped.
2. Connect an ohmmeter or continuity tester across (COM and B) terminal switch contacts. The ohmmeter should show an open circuit, no continuity.
3. Deflect the actuator lever and hold it until the pneumatic delay shaft releases the switch buttons. The ohmmeter or continuity tester should show a short circuit after the delay has elapsed. If there is no delay, check the setting of the delay adjustment dial.

**Figure 3. Field wiring:**

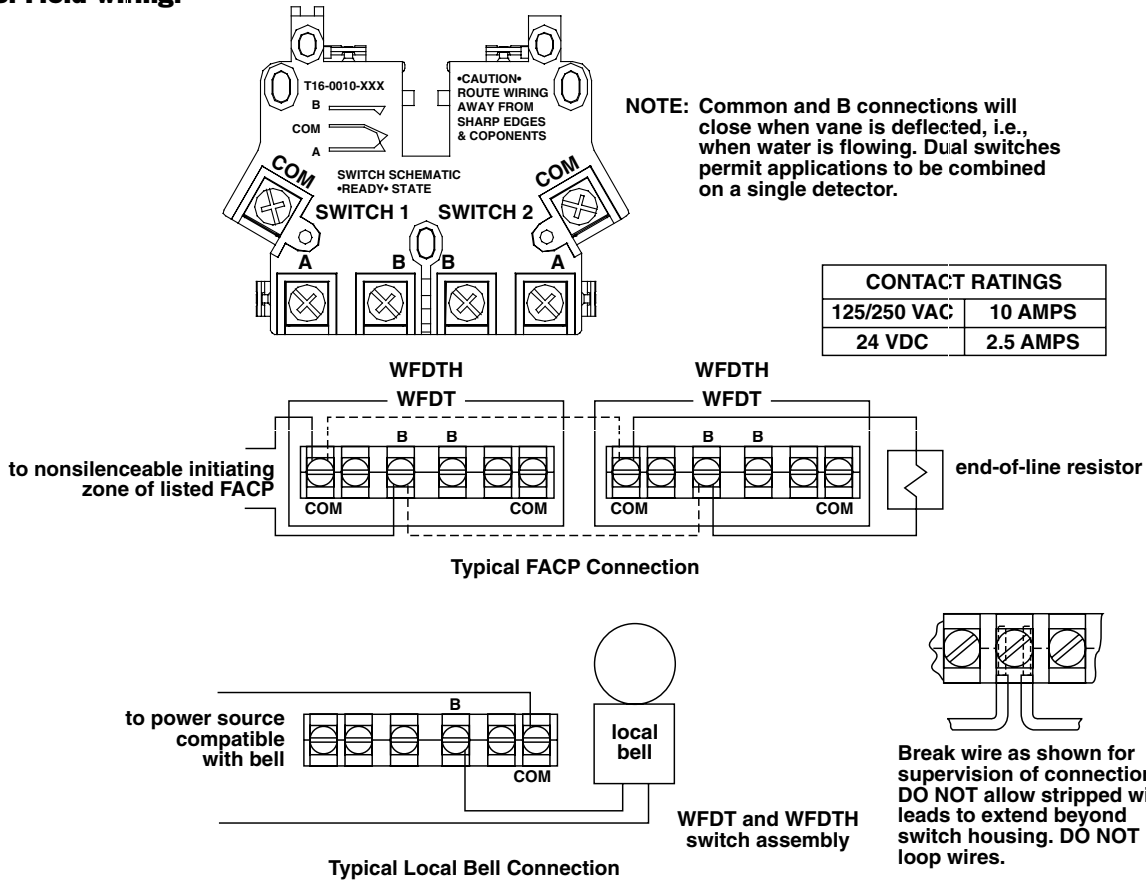

**Field Wiring**



High Voltage. Electrocutation Hazard. Do not handle live AC wiring or work on a device to which AC power is applied. Doing so may result in severe injury or death.

1. The WFDT and WFDTH have two SPDT switches. Switch contacts (COM and B) are closed when water is flowing and open when water is not flowing. Connect the switches as shown in Figure 3 depending on the application.
2. When connected to a listed sprinkler/fire alarm control panel, the initiating circuit must be non-silenceable.
3. A ground screw is provided with all units. When grounding is required, clamp wire with screw in hole located between conduit entrance holes. See Figure 2.

**Mechanical Delay Adjustment**

The pneumatic delay is preset at dial setting 2 at the factory. To adjust the delay, turn the adjustment dial on the delay mechanism. Turn clockwise to increase the delay, counterclockwise to decrease the delay. Delay can be adjusted over a range from 0-70 seconds. See Figure 4.

**NOTE:** Set the delay to the minimum required to prevent false alarms due to flow surges.

After extended service, parts of the detector may become worn reducing the delay time and causing false alarms. If this happens, increase the delay. If the delay is already at maximum, replace the mechanical delay assembly. Refer to Maintenance section for ordering replacement parts.

**Figure 4. Delay adjustment dial:**

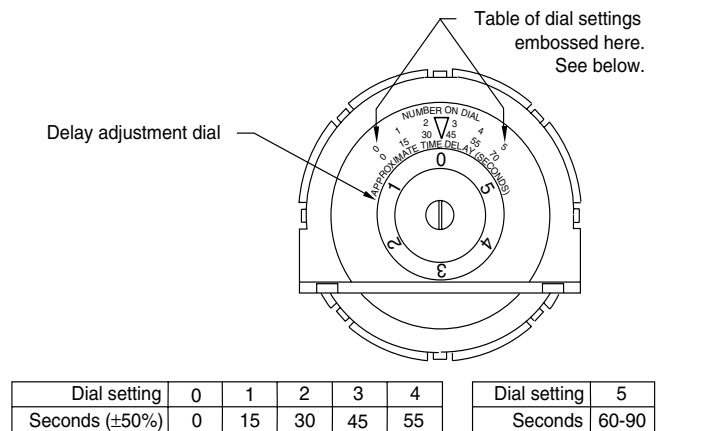

A78-1496-08

**NOTE:** Retard time may exceed 90 seconds. Adjust and verify that time does not exceed 90 seconds.

## Operational Testing

Always notify a central station monitoring waterflow alarms before repairing, maintaining or testing waterflow alarm devices.

1. Replace the cover and tighten the security screws with the tamper proof wrench. Store the wrench in a secure place.
2. Open the inspector's test valve and time how long it takes for the detector to indicate a flow condition. The detector should remain activated until the inspector's test valve is closed. Air pockets in the sprinkler system may increase the apparent time delay.

## Maintenance

To prevent accidental water damage, control valves should be shut tightly and the system completely drained before waterflow detectors are removed or replaced.

Inspect detectors monthly for leaks. Test detectors at least monthly as described under Operational Testing above to insure proper operation. This device is not designed for use on "dry pipe" systems. Test more often if required by the authority having jurisdiction.

Under normal conditions System Sensor waterflow detectors should provide years of trouble-free service. If, however, the delay mechanism becomes faulty, replacement

kits are available. To replace the delay mechanism, request Part No. A3008-00; for switch enclosure, request Part No. A77-01-02. Complete instructions are enclosed with each. Either mechanism can be easily replaced without removing the detector from the pipe or draining the pipe. If damage occurs to paddle, order replacement kit PRK9. Refer to procedure below for removal of detector on pipe. Do not repair or replace any other waterflow detector components in the field. If any other part of the detector does not perform properly, replace the entire detector. **Failure to follow this instruction may result in failure of the detector to report a waterflow condition.**

Proceed as follows to remove a detector.

1. Drain the pipe.
2. Turn off electrical power to the detector, and then disconnect wiring.
3. Unscrew WFDT or WFDTH from tee fitting.
4. Lift detector clear of pipe.

---

### **CAUTION**

If a vane breaks off in a pipe, find and remove it. Failure to do so may restrict the proper flow of water to part of the sprinkler system.

---

---

### **WARNING**

## The Limitations of Waterflow Alarm Devices

1. Waterflow detectors may not work or operate properly if sprinkler piping being monitored is plugged with pipe scale, mud, stones or other foreign material. Sprinkler systems should be checked regularly for such blocking material, following the instructions in Chapter 5 of NFPA Standard 13A.
2. Alarms generated by the activation of waterflow detectors may not be received by a central station if telephone or other communication lines to the detector are out of service, disabled, or open.
3. Vane-type waterflow detectors have a normal service

life of 10-15 years. Hard water systems, however, may substantially reduce waterflow detector service life.

4. Waterflow detectors are not a substitute for insurance. Building owners should always insure property and lives being protected by sprinkler systems.
5. If valves controlling the water supply to a sprinkler system are closed, vane-type waterflow detectors will not work. All valves controlling a sprinkler water supply should be sealed or locked in the normally open position. The normally open position should be monitored by a sprinkler supervisory switch.

## Please refer to insert for the Limitations of Fire Alarm Systems

### Three-Year Limited Warranty

System Sensor warrants its enclosed waterflow detector to be free from defects in materials and workmanship under normal use and service for a period of three years from date of manufacture. System Sensor makes no other express warranty for this waterflow detector. No agent, representative, dealer, or employee of the Company has the authority to increase or alter the obligations or limitations of this Warranty. The Company's obligation of this Warranty shall be limited to the repair or replacement of any part of the waterflow detector which is found to be defective in materials or workmanship under normal use and service during the three year period commencing with the date of manufacture. After phoning System Sensor's toll free number 800-SENSOR2 (736-7672) for a Return Authorization number, send defective units postage prepaid to: System Sensor, Return

Department, RA # \_\_\_\_\_, 3825 Ohio Avenue, St. Charles, IL 60174. Please include a note describing the malfunction and suspected cause of failure. The Company shall not be obligated to repair or replace units which are found to be defective because of damage, unreasonable use, modifications, or alterations occurring after the date of manufacture. In no case shall the Company be liable for any consequential or incidental damages for breach of this or any other Warranty, expressed or implied whatsoever, even if the loss or damage is caused by the Company's negligence or fault. Some states do not allow the exclusion or limitation of incidental or consequential damages, so the above limitation or exclusion may not apply to you. This Warranty gives you specific legal rights, and you may also have other rights which vary from state to state.