



Stock No. 1113000

U.S. Pat. No. 3921989, Canadian Pat. No. 1009680
Other Patents Pending

The Model VSR-SF is a vane type waterflow switch for use on wet sprinkler systems that use 1" (25mm), 1 1/4" (32mm), 1 1/2" (38mm) or 2" (50mm) pipe size. The unit may also be used as a sectional waterflow detector on large systems.

The unit contains two single pole double throw snap action switches and an adjustable, instantly recycling pneumatic retard. The switches are actuated when a flow of 8-10 gallons per minute (30-38 LPM) or more occurs downstream of the device. The flow condition must exist for a period of time necessary to overcome the selected retard period.

INSTALLATION: These devices may be mounted in horizontal or vertical pipe. On horizontal pipe they should be installed on the top side of the pipe where they will be accessible. The units should not be installed within 6" (15cm) of a valve, drain or fitting which changes the direction of the waterflow. Select the proper paddle for the pipe size and type of TEE used see Fig. 1 for instructions on changing paddle. The unit has a 1" NPT bushing for threading into a non-corrosive TEE. See Fig. 2 for proper TEE size, type and installation. Use no more than three wraps of teflon tape.

UL, ULC, CSFM Listed and NYMEA Accepted, CE Marked

Service Pressure: Up to 250 PSI (17,2 BAR)

Minimum Flow Rate for Alarm: 8-10 GPM (30-38 LPM)

Maximum Surge: 18 FPS (5,5 m/s)

Enclosure: Die-cast, red enamel finish

Cover held in place with tamper resistant screws

Contact Ratings: Two sets of SPDT (Form C)

15.0 Amps at 125/250 VAC

2.0 Amps at 30 VDC

Conduit Entrances: Two knockouts provided for 1/2" conduit.

Usage: Listed plastic, copper and schedule 40 iron pipe.

Fits pipe sizes - 1" (25mm), 1 1/4" (32mm), 1 1/2" (38mm) and 2" (50mm)

Note: 12 paddles are furnished with each unit, one for each pipe size of threaded and sweat TEE, one for 1" (25mm) CPVC, one for 1" (25mm) CPVC (Central), one for 1 1/2" (38mm) polybutylene and one for 1 1/2" (38mm) threaded (Japan).
(CTS-Copper tubing size)

Environmental Specifications:

- Suitable for indoor or outdoor use with factory installed gasket and die-cast housing.
- NEMA 4/IP55 rated enclosure - use with appropriate conduit fitting.
- Temperature range: 40° F to 120° F, 4,5° C to 49° C)

Caution: This device is not intended for applications in explosive environments.

Service Use:

Automatic Sprinkler	NFPA-13
One or two family dwelling	NFPA-13D
Residential occupancy up to four stories	NFPA-13R
National Fire Alarm Code	NFPA-72

Optional: Cover Tamper Switch Kit, Stock No. 0090018

Screw the device into the TEE fitting as shown in Fig. 2. Care must be taken to properly orient the device for the direction of waterflow.

The vane must not rub the inside of the TEE or bind in any way. The stem should move freely when operated by hand.

The device can also be used in copper or plastic pipe installations with the proper adapters so that the specified TEE fitting may be installed on the pipe run.

INSPECTION AND TESTING: Check the operation of the unit by opening the inspector's test valve at the end of the sprinkler line or the drain and test connection, if an inspector's test valve is not provided.

If there are no provisions for testing the operation of the flow detection device on the system, application of the VSR-SF is not recommended or advisable

The frequency of the inspection and testing and its associated protective monitoring system should be in accordance with the applicable NFPA Codes and Standards and/or authority having jurisdiction (manufacturer recommends quarterly or more frequently).

FIG. 1

Retard Adjustment:

To change time, turn knob (either direction) for desired time delay. Use the minimum amount of retard necessary to prevent false alarms. A "B" setting is usually adequate for this. Factory set at "B".

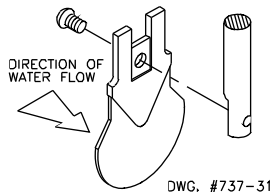

DWG. #737-31

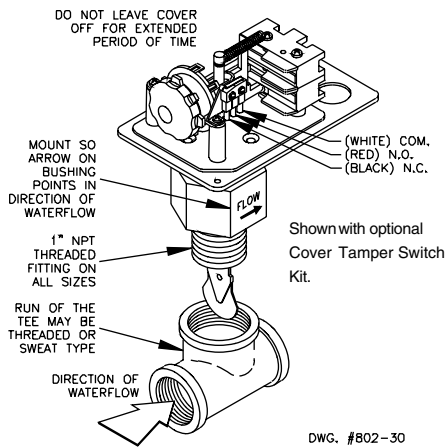

DWG. #802-30

Important:

There are 12 paddles furnished with each unit. One for each size of threaded, sweat or plastic TEE as described in Fig. 2. These paddles have raised lettering that shows the pipe size and type of TEE that they are to be used with. The proper paddle must be used. The paddle must be properly attached (see drawing) and the screw that holds the paddle must be securely tightened.

CAUTION: TO PREVENT LEAKAGE APPLY TEFLON TAPE SEALANT TO MALE THREADS ONLY. DO NOT USE ANY OTHER TYPE OF LUBRICANT OR SEALANT.

APPROX. RETARD SETTINGS (IN SEC.)					
0	A	B	C	D	E
0	10-25	20-40	35-55	50-70	60-90

FIG. 2

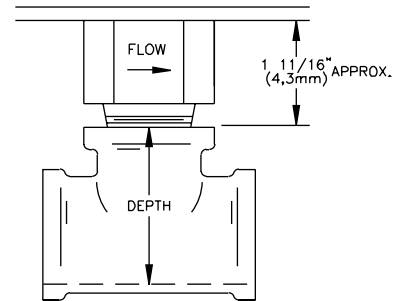

Screw the device into the tee fitting as shown. Care must be taken to properly orient the device for the direction of waterflow. On sweat tees, no threaded bushings, inserts, or adapters are permitted, unless they comply with the dimensions listed in the chart below.

Important - The depth to the inside bottom of the tee should have the following dimensions:

TEE SIZE	APPROXIMATE DEPTH REQUIREMENT			
	THREADED	SWEAT	CTS, POLYBUTYLENE	CPVC
1" x 1" x 1"	2 1/16"	1 3/4"	N/A	2 7/16"
1 1/4" x 1 1/4" x 1"	2 7/16"	2 7/16"	N/A	N/A
1 1/2" x 1 1/2" x 1"	2 11/16"	2 1/4"	2 1/2"	N/A
2" x 2" x 1"	3 3/16"	2 3/4"	N/A	N/A

DWG. #735-33

Warning: Do not use more than three wraps of teflon tape.

SWITCH TERMINAL CONNECTIONS CLAMPING PLATE TERMINAL

FIG. 3

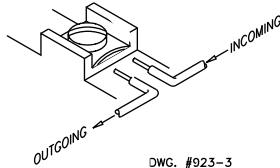

DWG. #923-3

CAUTION:

An uninsulated section of a single conductor should not be looped around the terminal and serve as two separate connections. The wire must be severed, thereby providing supervision of the connection in the event that the wire becomes dislodged from under the terminal.

FIG. 4 TYPICAL ELECTRICAL CONNECTIONS

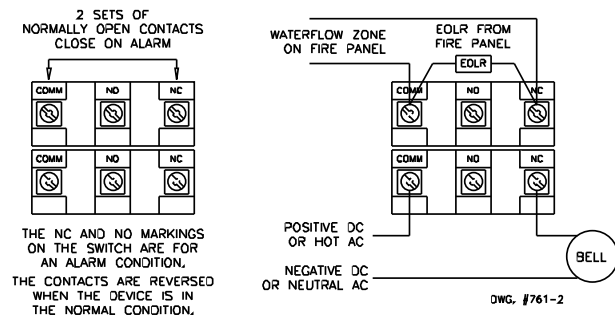

DWG. #761-2

FIG. 5

To remove knockouts: Place screwdriver at edge of knockouts, not in the center.

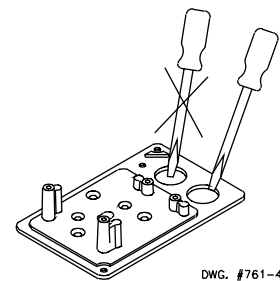

DWG. #761-4

NOTES:

- The model VSR-SF has two switches, one can be used to operate a central station, proprietary or remote signaling unit, while the other is used to operate a local audible or visual annunciator.
- For supervised circuits see "Switch Terminal Connections" drawing and caution note (Fig. 3).

APPLICATION WARNING!

Due to the possibility of unintended discharges caused by pressure surges, trapped air, or short retard times, waterflow switches that are monitoring wet pipe sprinkler systems should not be used as the sole initiating device to discharge AFFF, deluge, or chemical suppression systems.